

UNCONTROLLED DOCUMENT

PART NUMBER		REV.
GT-CM3145L		B
REV.	E.C.N. NUMBER AND REVISION COMMENTS	DATE
A	E.C.N. #10BRDR. & 10912.	9.24.02
B	E.C.N. #11148.	12.11.06

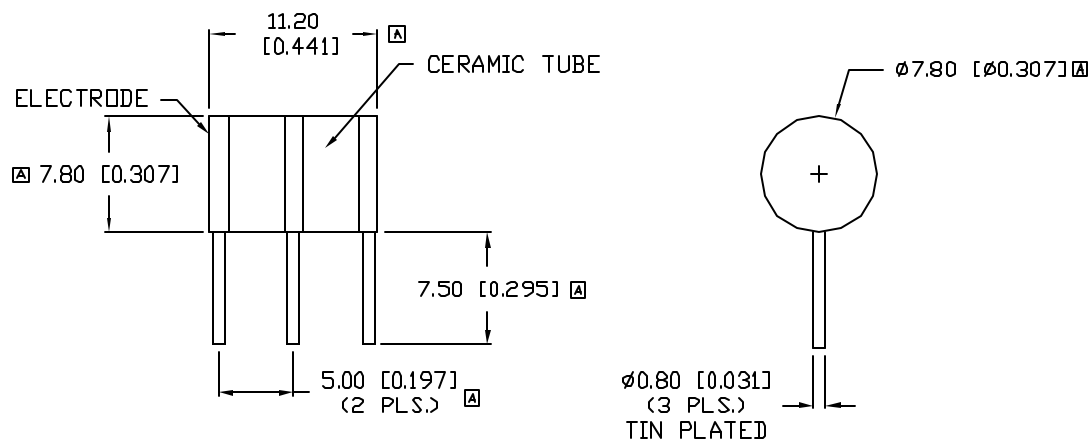

ELECTRICAL SPECIFICATIONS

PARAMETER	VALUE	TEST CONDITION
D.C. FIRING VOLTAGE:	145V±20% D.C.	{dv/dt 100V/S}
IMPULSE FIRING VOLTAGE:	500V D.C. MAX.	{dv/dt 100V/μS}
IMPULSE CURRENT:	10KA MAX.	{8/20μS}
D.C. HOLDOVER VOLTAGE:	70V D.C. MAX.	{10/1000μS 500A}
A.C. DISCHARGE CURRENT:	65A	{50Hz, 9 CYCLES}
INSULATION RESISTANCE:	10 <sup>4</sup> MΩ MIN.	{50 OR 100VDC}
INTER-ELECTRODE CAPACITANCE:	2.0 PF MAX.	1.0kHz

ENVIRONMENTAL SPECIFICATIONS PER MIL-STD 202

TEST	METHODE	CONDITION	RATING
VIBRATION TESTING:	204B	C	10-55HZ., 06DA
SHOCK	213A	C	100G
HUMIDITY:	103B	B	95%RE.HUMIDITY
TEMPERATURE CYCLING:	102A	C	- 65 TO + 125 °C
BAROMETRIC PRESSURE:	105C	B	50,000FT.
THERMAL SHOCK:	107	B	- 65 TO + 125 °C
SOLDERABILITY:	20B	B	

RESPONSE TIME

SURGE TYPE	(Rt MAX.)
1Kv/mS	1 x 10 <sup>-5</sup> sec.
1Kv/μS	1 x 10 <sup>-6</sup> sec.
5Kv/μS	1 x 10 <sup>-9</sup> sec.



\*UNLESS OTHERWISE SPECIFIED TOLERANCES PER DECIMAL PRECISION ARE: X=±1 (±0.039), X.X=±0.5 (±0.020), X.XX=±0.25 (±0.010), X.XXX=±0.127 (±0.005). LEAD SIZE=±0.05 (±0.002), LEAD LENGTH=±0.75 (±0.030), MIN= <sup>+DECIMAL PRECISION</sup> <sub>-0.00</sub> MAX.= <sup>+0.00</sup> <sub>-DECIMAL PRECISION</sub>

UNCONTROLLED DOCUMENT

REV.	PART NUMBER
B	GT-CM3145L

CONFIDENTIAL INFORMATION  
 THE INFORMATION CONTAINED IN THIS DOCUMENT IS THE PROPERTY OF LUMEX INC. EXCEPT AS SPECIFICALLY AUTHORIZED IN WRITING BY LUMEX INC, THE HOLDER OF THIS DOCUMENT SHALL KEEP ALL INFORMATION CONTAINED HEREIN CONFIDENTIAL AND SHALL PROTECT SAME IN WHOLE OR IN PART FROM DISCLOSURE AND DISSEMINATION TO ALL THIRD PARTIES.



290 E. HELEN ROAD  
 PALATINE, IL 60067-6976  
 PHONE: +1.847.359.2790  
 US WEB: www.lumex.com  
 TW WEB: www.lumex.com.tw

T8 x T11 CERAMIC ARRESTOR, 3 LEADED 145V, DC.

RELIABILITY NOTE  
 OUR MANY YEARS OF EXPERIENCE DATA ACCUMULATION INDICATE THAT SOLDER HEAT IS A MAJOR CAUSE OF EARLY AND FUTURE FAILURE. PLEASE PAY ATTENTION TO YOUR SOLDERING PROCESS.

DRAWN BY:	CHECKED BY:	APPROVED BY:	DATE: 12.11.06
JC			PAGE: 1 OF 1
			SCALE: N/A